

SMX
series

Self-priming magnetic drive pumps

Magnetic drive pumps with an excellent balance
of features and performance



Main material
GFRPP

Self-priming magnetic drive pumps

The SMX is a horizontal self-priming magnetic drive pump made from reinforced plastic. Our original self-radiation structure enhances resistance to abnormal operations.

Patent

JAPAN / U.S.A. / EU / CHINA / TAIWAN

Versatile self-priming magnetic drive pump with enhanced durability under abnormal operation



The SMX is a horizontal self-priming magnetic drive pump made from reinforced plastic. Our original self-radiation structure (Patented) enhances resistance to dry running, cavitation, and closed-discharge operation. In addition, the use of standard motors extends the range of application.



SMX-543

SMX-441

SMX-220

Expanded versatility

The SMX has a modular structure to handle liquids with high specific gravities. Use of standard motors extends the range of liquid application.

Easy maintenance

The pump wet end can be removed from the motor as a complete assembly without dismantling, thanks to an additional rear casing support. The pump wet end comprises the minimum number of parts for easy maintenance.

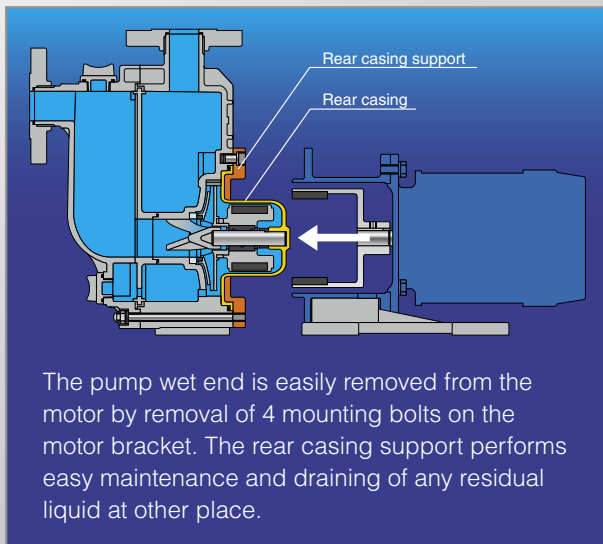

Enhanced durability under abnormal operation

Our original self-radiation structure (Patented) efficiently disperses bearing friction heat to protect the pump under abnormal operating conditions. In addition, our non-contact structure prevents contact between rear thrust face and bearing, to eliminate heat buildup during dry running.

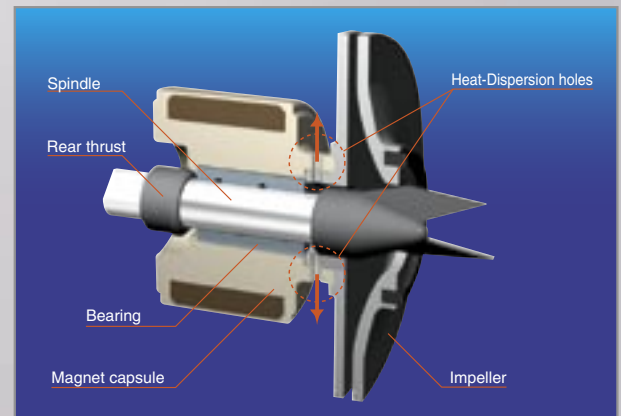

Fast self-priming

The SMX requires no external self-priming chambers or valves. The gas-liquid separation design ensures fast self-priming. An exceptional self-priming duration of up to 4m in only 90 seconds is now possible.

Examples of application

Pumping up from underground tank

- Underground tank at chemical plant.
- Underground tank or pit of waste plant.

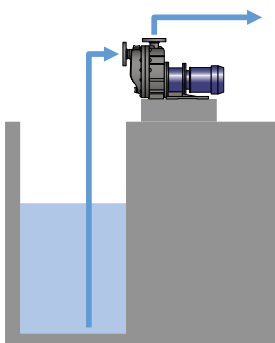

Pumping up and out from top of tank and tanker truck

- Transferring etching and plating chemical from chemical bath.
- Sucking up chemical from truck.
- Pumping up from top of tank.

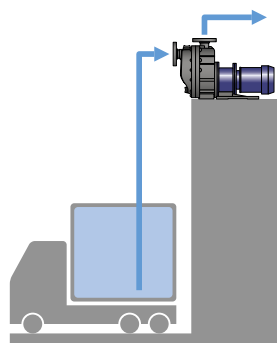

Transferring chemical from tank to tank

- Transferring from main tank to daily tank.
- Refilling chemical from drum to tank.

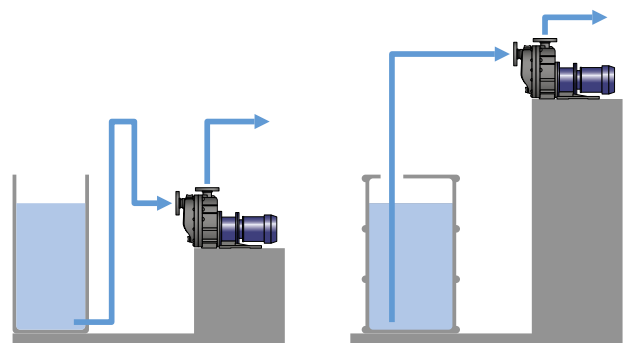

Reliability and performance are enhanced by our unique design

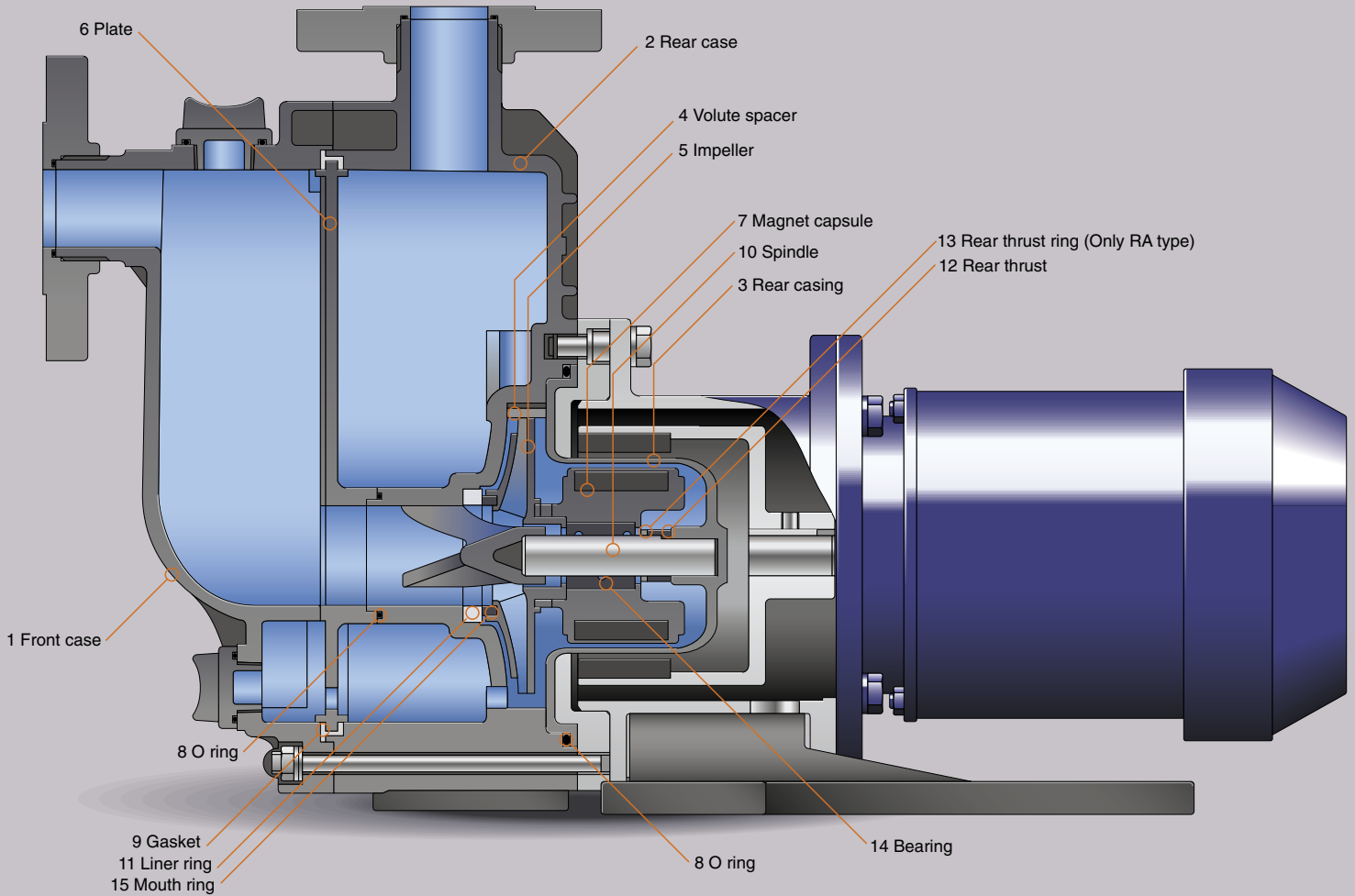

Wet-end materials

Name of part	Model		
	CA	RA	KA
1 Front case			
2 Rear case			
3 Rear casing			
4 Volute spacer <small>Note1</small>		GFRPP	
5 Impeller			
6 Plate			
7 Magnet capsule		PP	
8 O ring		FKM/EPDM	
9 Gasket			
10 Spindle	High purity alumina ceramic		SiC
11 Liner ring		Alumina ceramic	
12 Rear thrust <small>SMX-22, 44</small>		CFRPPS	
<small>SMX-54</small>	High purity alumina ceramic		SiC
13 Rear thrust ring <small>Note2</small>	-	Alumina ceramic	-
14 Bearing	Carbon	PTFE (With filler)	SiC
15 Mouth ring		PTFE (With filler)	

Note1 : SMX-22□T, 54□T, 54□X do not have a Volute spacer

Note2 : Exclusive for SMX-22RA, 44RA



Principles of Self-Priming

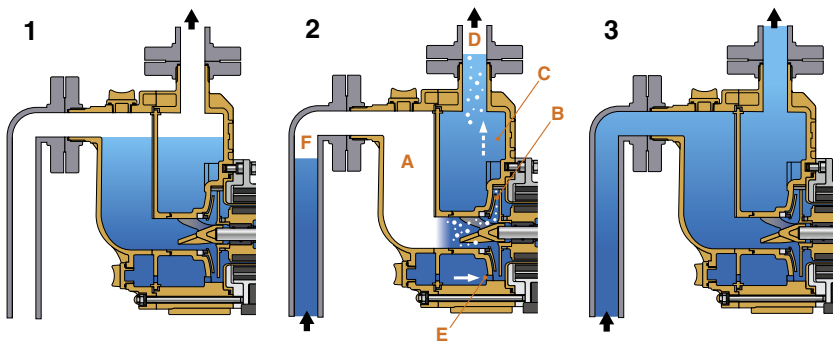

1 Prime the pump with liquid.

2 On starting, the pump will suck both gas and liquid into its inlet. This mixture moves through front case **A** to the front casing, where it is agitated by the impeller. The mixture is discharged through pump chamber **B** to rear case **C**, where gas and liquid separation then occurs. Gas is bled from the discharge port **D** while some liquid is retained. Liquid in the rear case **C** is fed back through circulation hole **E** to the front casing, where it is again mixed with entrained gas by the impeller. This recirculation & bleeding process continues until gas from the suction side **F** is completely expelled.

3 Once all gas is expelled, normal centrifugal pump operation is resumed. Sufficient liquid remains in the casing for subsequent self-priming once the pump is stopped.

Specifications

Model	Connection Suction X Discharge (mm)	Impeller	Cycle (Hz)	Min. capacity (L/min)	Standard specification (L/min-m)	Max. capacity (L/min)	Motor (kW 2p)	Resisting pressure limit (MPa)	Mass (kg)									
SMX-220	25 X 25	V	50	10	80 - 8.5	90	0.4	0.28	22									
		Y	60		80 - 8.0	90												
		T	50		100 - 13.0	160												
SMX-221		25 X 25	V		50	10	80 - 8.5		140	0.75	0.28	28						
			X		60		100 - 13.0		170									
			Y		60		80 - 8.0		135									
SMX-222			25 X 25		T		50		10	100 - 13.0		160	1.5	0.28	32.5			
					X		60			100 - 13.0		170						
SMX-441					40 X 40		T			50		10	150 - 12.4			190	0.75	0.33
	Y			60			150 - 11.5	200										
	T			50			150 - 12.4	280										
SMX-442	40 X 40			X			60	10		200 - 18.0			310		1.5	0.33	33	
		Y		60		150 - 11.5	290											
SMX-443		40 X 40		X		60	10			200 - 18.0	345		2.2		0.33			
				T		50				200 - 18.0	440							
SMX-542			50 X 40	V		50			20	200 - 17.0	230		1.5	0.43			40	
				T		50				250 - 18.0	440							
				SMX-543	50 X 40	V				50	20	200 - 17.0						410
Z						60				250 - 18.0		440						
SMX-545						50 X 40				T		50	20				250 - 18.0	440
	V			50				200 - 17.0		410								
	X			60				300 - 26.0		520								
SMX-545	50 X 40	Y		60			20	300 - 22.3		500		3.7			0.43	60		
		Z		60				250 - 18.0		440								

- The self-priming height limit noted above refers to a liquid equivalent to fresh water at 20°C. The self-priming height limit varies with the liquid temperature and the type of liquid.
- Temperature range of handled liquid: 0 to 80°C (The self-priming height limit decreases at high temperatures.)
- Mass weight includes a outdoor motor.

Pump identification

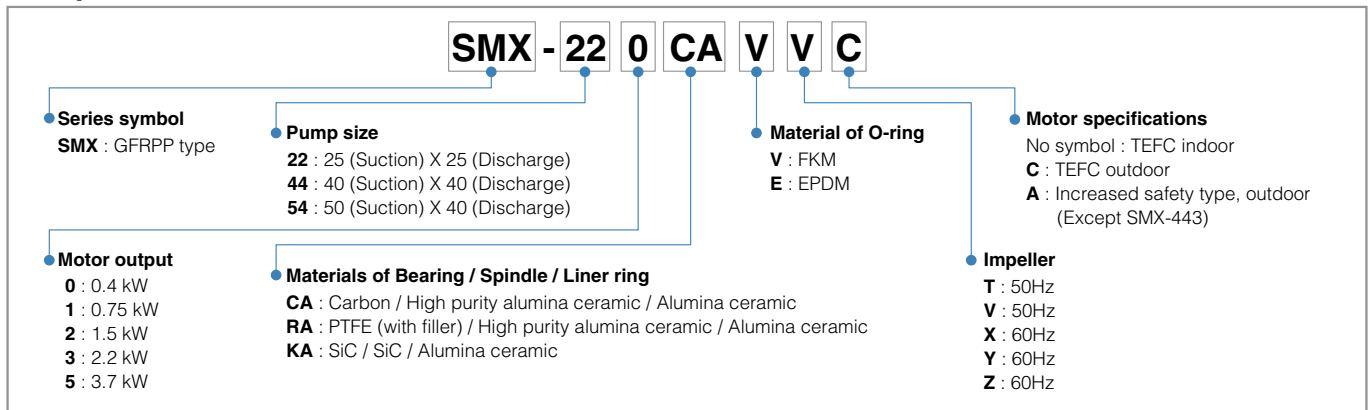

Precautions on the selection of pumps

- The performance curves on this catalogue are based on the operation with 20°C clean water in flooded suction. Keep a margin (3% of the curves) when selecting the pump.
- The magnetic pump cannot run continuously with a closed-discharge. Be sure to observe the minimum flow rate.
The minimum flow rate SMX-22□: 10L/min
SMX-44□: 10L/min
SMX-54□: 20L/min
- Select a pump model according to liquid specific gravity. Keep a margin (5% or more) for motor output.
Pump shaft power Sp × Specific gravity × 1.05 or more (margin) ≤ Motor output
- The self-priming performance (4m in 90 seconds) is based on the operation with 20°C clean water on the right piping condition. Self-priming performance varies with liquid temperature, characteristics and piping conditions. Obtain a rough guide of the highest possible self-priming height at each liquid specific gravity by the following formula.
The highest possible self-priming height[m] = Self-priming height with clean water[m] / Liquid specific gravity

Self-priming considerations

- The diameter of the piping on the suction side should be the same as that of the pumps inlet port,
SMX-22□ : 25mm
SMX-44□ : 40mm
SMX-54□ : 50mm
and the length of the piping should be limited to less than 4.7m. A larger pipe diameter or longer piping could adversely affect the self-priming performance, or could even hinder the self-priming process itself.
- In cases where the liquid level fluctuates, take the height from the lowest liquid level as the maximum self-priming height.
- Always perform priming before first operation, and start the pump only after the pump chamber has been filled with the handled liquid.
- To prevent early deterioration, avoid frequent start/stop of the pump.
- If a foot valve is installed on the suction pipe, pipe resistance may increase so that the pump cannot suck liquid enough.

Performance curves

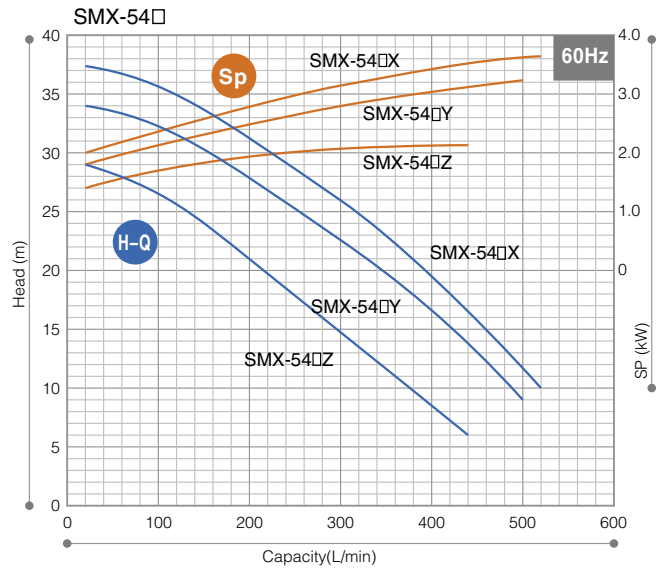
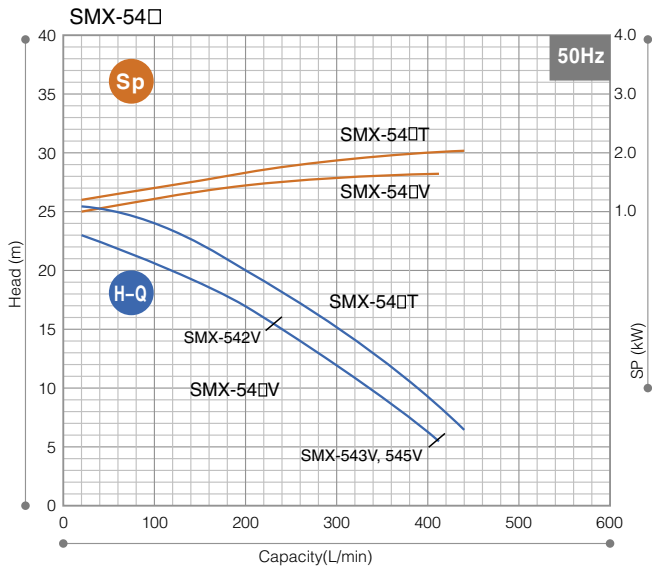
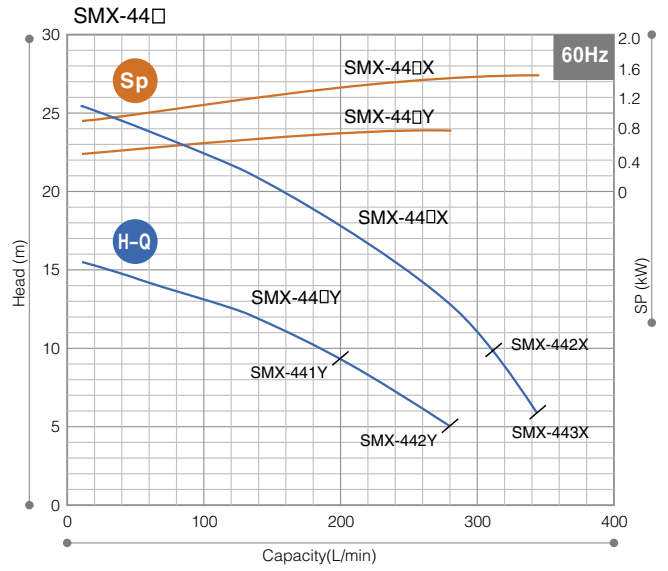
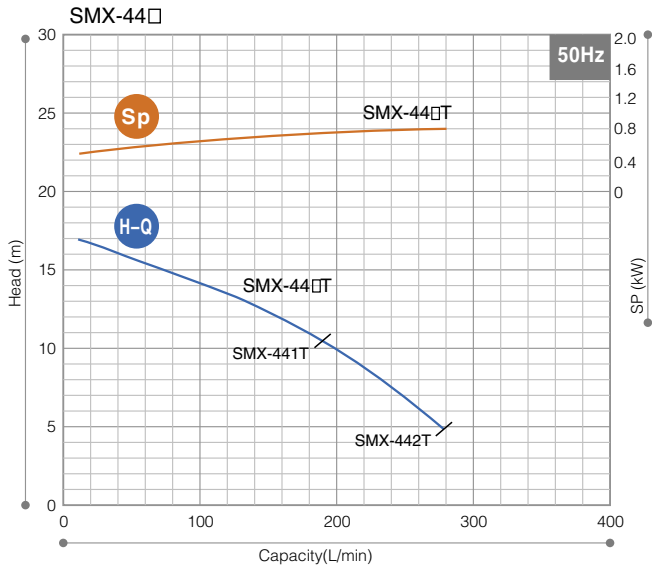
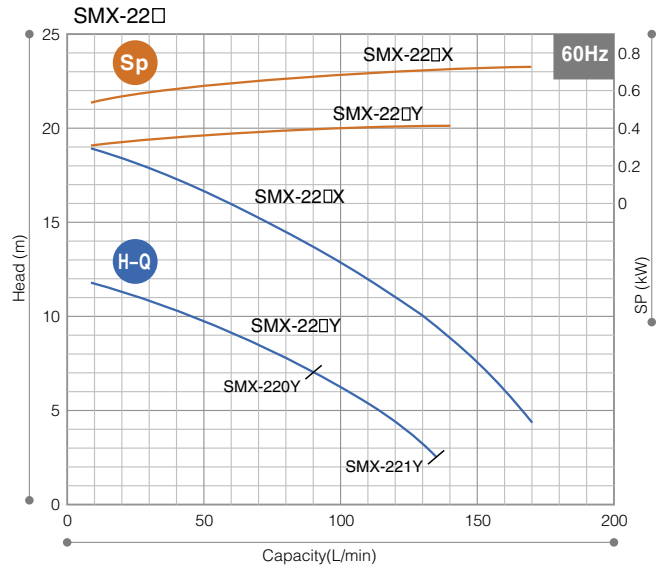
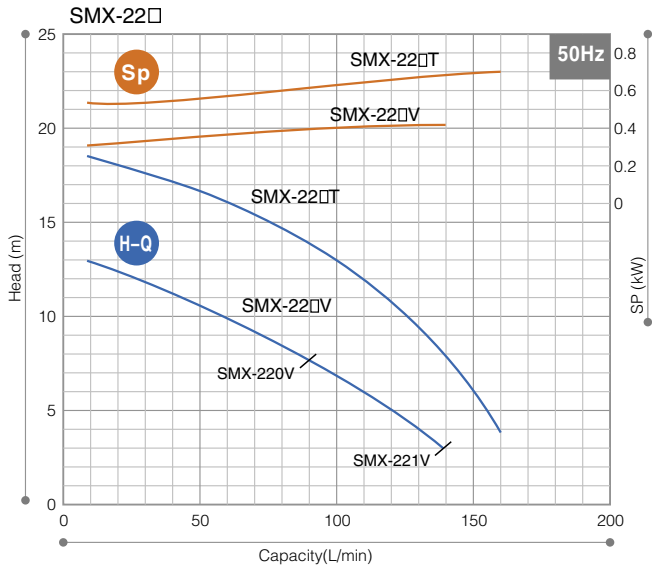

Dimensions in mm

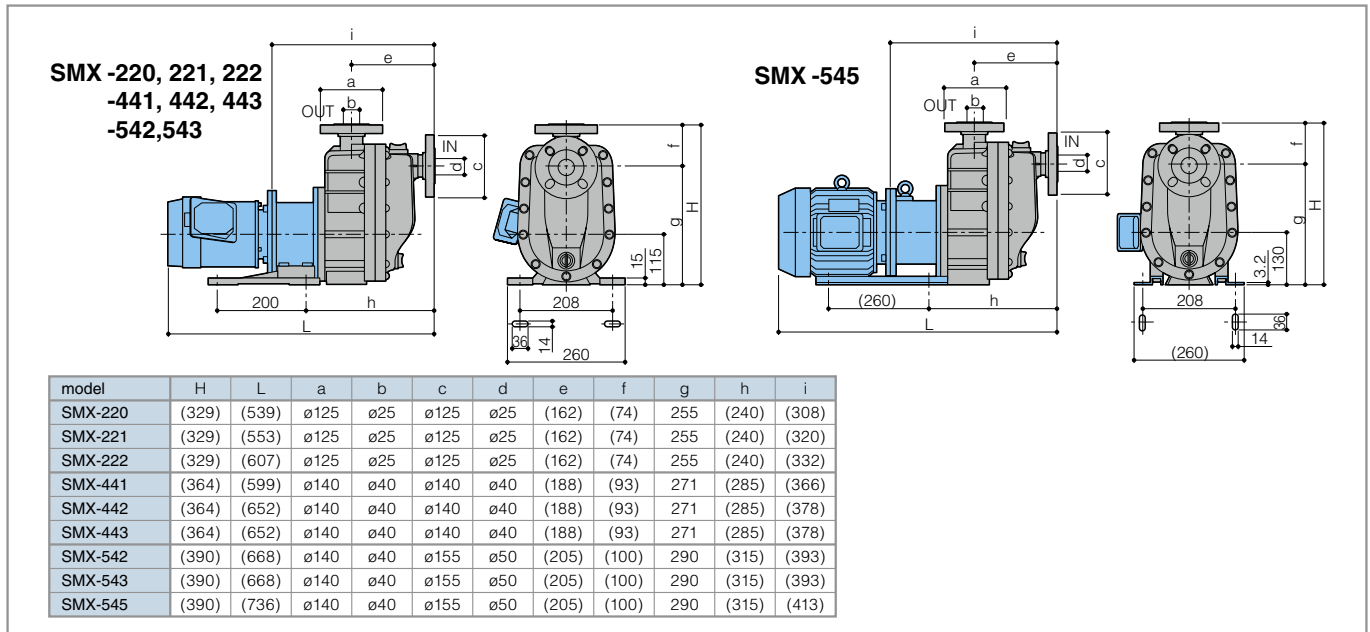

Optional accessories

Iwaki dry running protector DR series

Model DR is electric current sensing type dry running protector. It detects the decreased load current (lower limit) to stop the pump when it runs dry or runs with air sucking in. It can detect over-load, too.

- Current figure to be set is indicated on LCD.
- Both top/bottom figures can be set.
Top: Over-load
Bottom: Dry running, air sucking-in operation, operation with suction side closed
- Built-in current transformer
- DIN rail mounting
- It is unable to use DR when inverter is employed in the system.



Specification

50/60Hz

Model	DR-10, DR-20	
Motor power (50/60Hz)	200 to 240V three phase	380 to 440V three phase
Applied motor (50/60Hz)	0.4kW to 0.75kW	0.75kW to 15kW
Power control (50/60Hz)	100V to 240V single phase	
Power	V	100V ±10% single phase (DR-10), 200V to 240V ±10% single phase (DR-20)
	Input	3.5W
Detective current	0.5A to 32.0A	
Current transformer (CT)	Built-in	
Outer dimension	D80 X W153 X H122	